

Picotest

P9610A & P9611A

Mixed Mode DC Power Supply

Data Sheet



PICOTEST CORP.

Key Features

Mixed Mode:

Switched Efficiency plus
Linear Performance

Programming Accuracy:

V: 0.05% + 10mV
C: 0.2% + 10mA

Line & Load Regulations:

V: 0.01% + 2mV
C: 0.01% + 25 μ A

Autoranging:

P9610A: 1mV~36V, 1mA~7A
P9611A: 10mV~60V, 1mA~6A

Fast Transient Response Time:

P9610A: <30 μ s
P9611A: <50 μ s

Ripple & Noise:

20Hz to 20MHz
P9610A: <350 μ Vrms
P9611A: <500 μ Vrms

Master / Slave Control:

Various Connections with 7
pieces P9610As can enlarge
the output up to 252V / 49A or
stimulate multi-outputs.

Sequencing Mode:

8 Programmable Points
Control

Save & Recall:

16 memory states

Remote Sense:

Stable & Accurate Output

Output & Protection:

CV, CC / OVP, OCP, OTP

An Optical Knob:

Provides a Durable & Precise
Control

Standby Output for Safety:

When turning on the power,
the output is disabled.

Security Lock:

Keypad lock, and physical lock
mechanism

Light Weight:

Size: 214.6W*88.8H*280D mm
Weight: 2500g, Approx. 5.5 Lbs

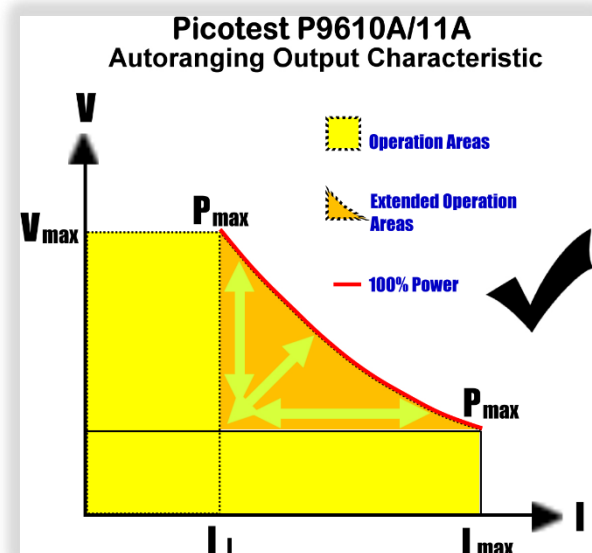
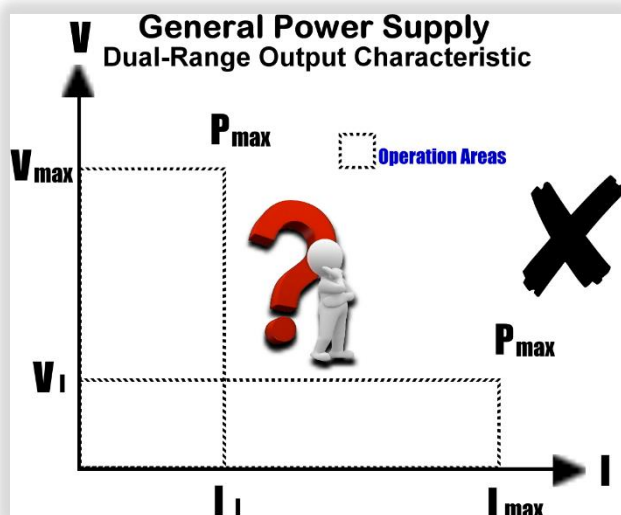

Figure1. The P9610A 108W and P9611A 150W mixed mode DC power supplies

Advanced Function – Autoranging

The P9610A features the autoranging capability, while other power supplies require the user to switch ranges to maximize output power.

The P9610A/11A provides the extended operation areas (see below). This means that you have access to 100% power all the time at any voltage or current within the maximum limits. This also means that the P9610A/11A can meet more of your needs, minimizing the number and cost of power supplies you need to purchase.



Versatile Connection – Master / Slave Control

The P9610A supports Master-Slave connections to increase the maximum output power to 252V / 49A. In addition, this capability can be also used to create sophisticated multi-output power systems, for example:

Triple Output

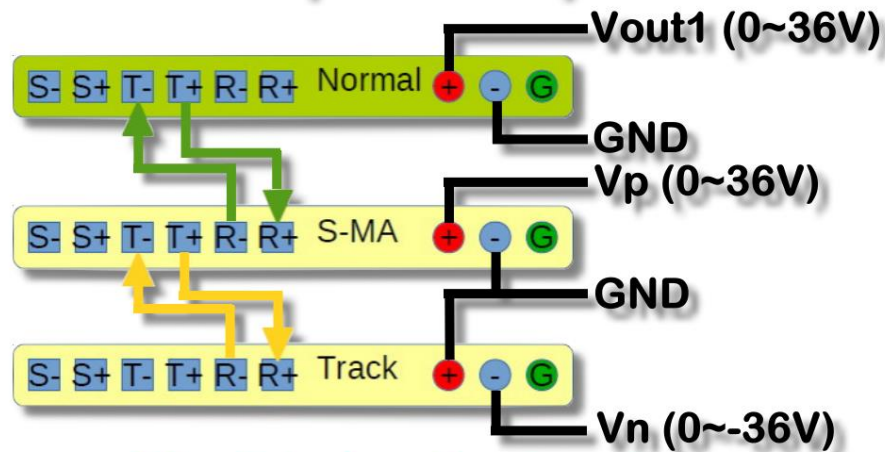

Multiple Output

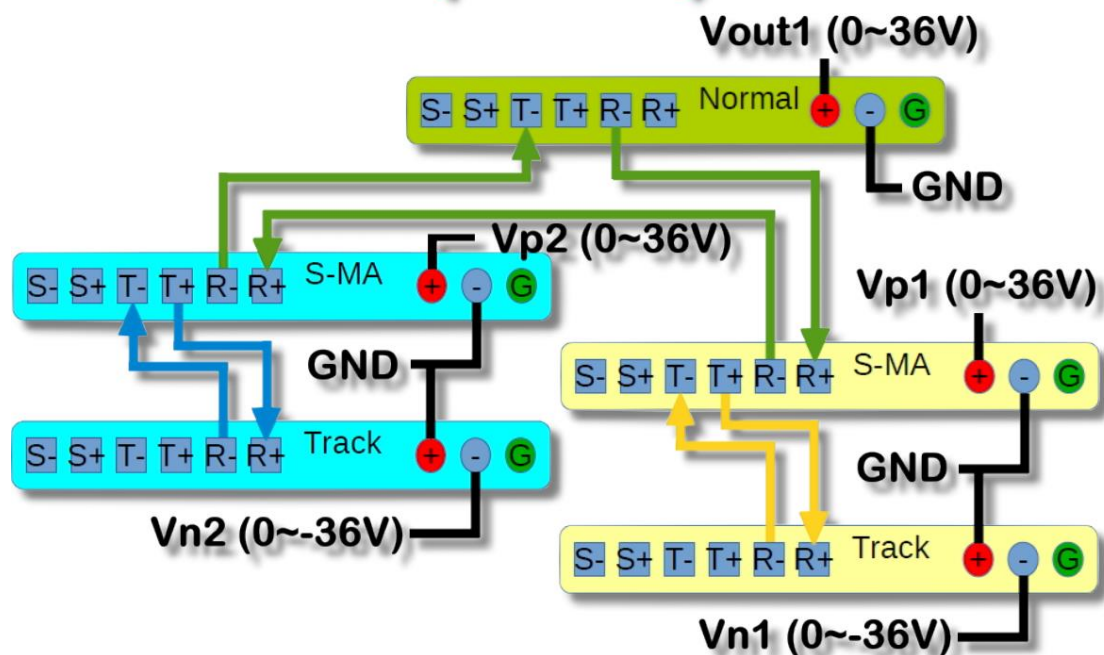

Cooling System – Evolution Advanced Fan

The P9610A/11A provides an efficient internal cooling system. The advanced technology fan minimizes distracting and annoying acoustic noise. You won't even notice the fan. Experience the evolution of the cooling system.



Fast Recovery – Load Transient Response Time

The P9610A recovers fast from large load current changes. The following oscilloscope images show the power supply response to 7A to 3.5A load change. It recovers to 15mV in 13.6 μ s. On the contrary, a well-known competitor's model under the same test conditions shows 25.6 μ s.

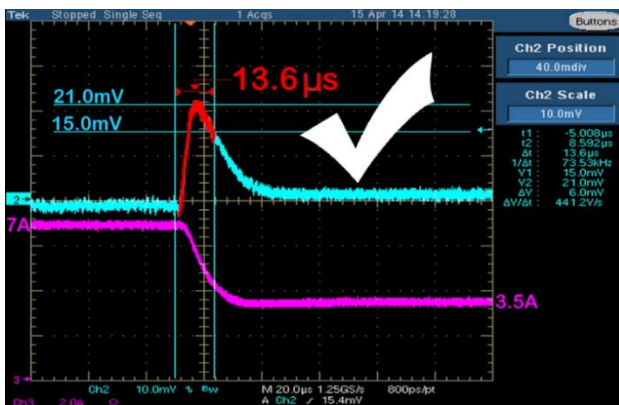

P9610A

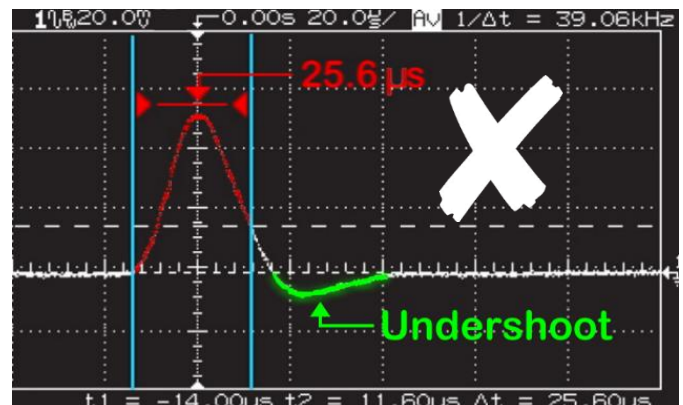

E3632A

The P9610A also has a smaller excursion and is more stable. Note the recovery undershoot in green in the competitor's power supply below. This does not exist in the P9610A. It is more precise.

Elegant Design – Knob & No Shorting Bar

Knob: The P9610A/11A provides a precise and durable adjustment knob. This optical knob has a numerical capability. Rotating it with the right or left direction button, you can move the cursor among the digits and numbers on the display. The optical control will not degrade like the potentiometers used in competing products.



No Shorting Bar: The P9610A provides a selectable circuit that eliminates the complexity of shorting bars when using remote sensing. The P9610A allows you to implement remote sensing or not at any time, providing the maximum flexibility. With the P9610A, there are no shorting bars to misplace and no time required to install them saving you time and money.



Protection Evolution I – Short-Withstood Circuit

The P9610A/11A can withstand continuous short circuits or repetitive short circuits up to 13 times per second. This is much more robust than many competing power supplies. The P9610A/11A incorporates a unique design which can protect itself instantaneously from abnormal and unpredictable events.



Protection Evolution II – OVP / OCP / OTP

Overvoltage protection (OVP), overcurrent protection (OCP), and over temperature protection (OTP) are exclusively designed to protect both the P9610A/11A and your DUT (Device under Test).



Pure Source – Low Noise Output

The P9610A can generate pure source with the low noise around 1.26mVp-p in the bandwidth from 20Hz to 20MHz. The well-known competitor's model under the same test conditions shows 1.98mVp-p.

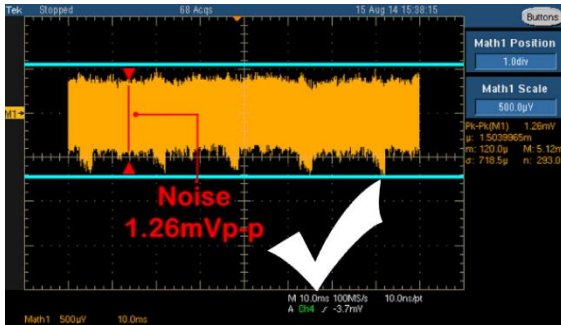

P9610A

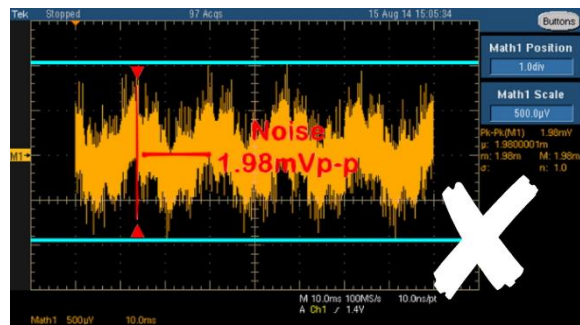

E3632A

Programmable Output – SEQ Function

Many digital circuits require power supplies to turn on & off in a particular order. The P9610A/11A supports the output voltage sequencing mode. This mode allows you to control the timing to output different voltages and currents.

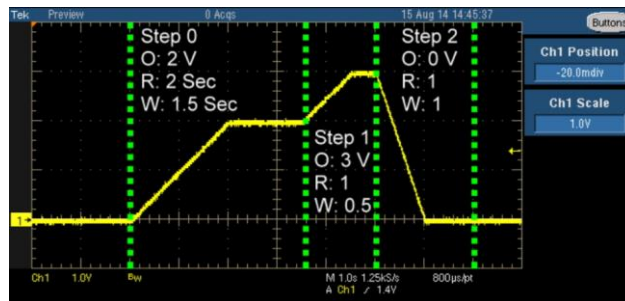

Other Features – Fast Settling & Compact Size

Settling Time: The advanced driver circuit of the P9610A/11A is very fast (40ms/<50ms) allowing you to improve your production throughput.



Compact Size: The P9610A/11A's weight is less than 2.5Kgs. The low weight of the P9610A/11A is less expensive to ship, saving you money.

Hidden Barrier-Free Carrying Handle: The handle conveniently stores out of the way allowing equipment to be safely stacked.

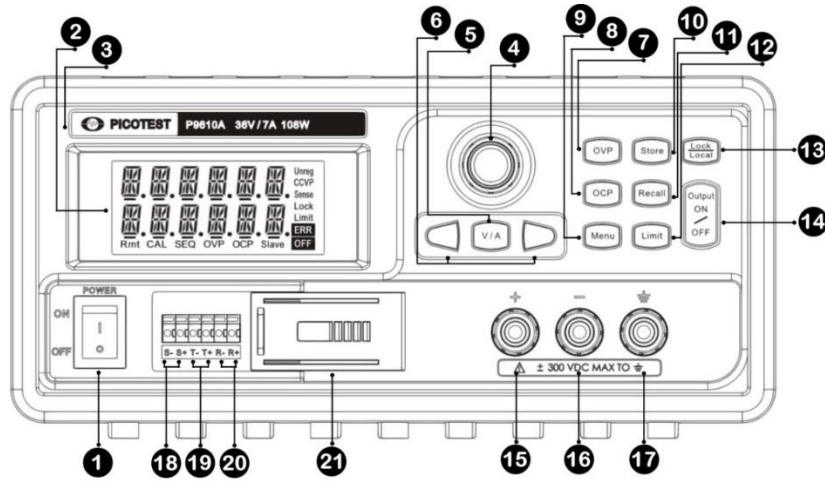

Features of the P9610A & 9611A



1. **Power Switch:** Press the (I) side to turn the power on and the (O) side to turn the power off.
2. **Display:** During operation, the display shows information about the output (top row) for voltage, and (bottom row) for current. During configuration, the display shows a control interface.
3. **Brand & Model Sticker Area:** This area shows the product manufacturer and model name.
4. **Navigation Wheel:** Rotate this knob to increase or decrease the flashing digit by turning the knob clockwise or counter-clockwise. It is also used to select menu items.
5. **V/A Button:** Press this button to change the output from Volts to Current or Current to Volts. Pressing this button long under the SEQ mode in output condition, the display will show the information of V & A, V & W, or SEQCNT.
6. **Arrow Buttons:** Press  once. The display cursor moves right one digit. Press  once. The display cursor moves left one digit. Pressing these buttons under the Store and the Recall, you can see the set parameters.
7. **OVP Button:** Enable or disable the overvoltage protection function, set the trip voltage level, and clear overvoltage condition.
8. **OCP Button:** Enable or disable the overcurrent protection function, set the trip current level, and clear overcurrent condition.
9. **Menu:** This button accesses the function settings. When the Menu button is pressed, and the knob is rotated, the display will show SENSE, MA/SL, SEQ, SYSTEM, CAL, and GPIB one by one. This button is also used to answer "Yes", i.e. "Confirmed" or "Applied."

10. **Store Button:** Store an operating state at the location 0, 1, 2... or 15.
11. **Recall Button:** Recall a previously stored operating state from the location 0, 1, 2... or 15.
12. **Limit Button:** Press it to show the voltage and current limit values on the display and allow the knob adjustment to set the limit values.
13. **Lock/Local Button:** When pressing the **LOCK** button, the Lock annunciator on the display is lit, and the Lock function is enabled until the same button is pressed once again. This button can be used as the Local Key when the power supply is operating under the remote interface mode.
14. **Output On/Off Button:** Enable or disable the power supply output. This key toggles between on and off.
15. **Positive Terminal:** Red terminal outputs positive voltage.
16. **Negative Terminal:** Black terminal outputs negative voltage.
17. **GND Terminal:** Terminal is at earth potential. Used for measurement of control circuits designed to be operated with one terminal at earth potential.
18. **Sensing Terminal (S+/S-):** The Remote Sensing Terminal is used to compensate for load current dependent voltage drops.
19. **Transfer Terminal (T+/T-):** Under the Master-Slave Mode, the master unit's T+ connects to the first slave unit's R+. Then its R- connects to the other unit's R+, and so on. The last slave unit's R- connects to the master unit's T-.
20. **Recipient Terminal (R+/R-):** Under the Master-Slave Mode, the master unit's T+ connects to the first slave unit's R+. Then its R- connects to the other unit's R+ and so on. The last slave unit's R- connects to the master unit's T-.
21. **Remote Sensing Cover:** This cover is used to protect against moisture and dust.

- **Note:** The P9611A doesn't provide the Items from 18 to 21.

Accessories

1. USB
2. USB + GPIB
3. Front & Rear Bumpers



P9610A Specifications

Output Ratings (@ 0 °C ~ 40 °C)

Voltage: 0 to 36 V
Current: 0 to 7 A

Programming Accuracy¹ 1 Year (@ 25 °C ±5 °C), (% of Output + Offset)

Voltage: 0.05% + 10 mV
Current: 0.2% + 10 mA

Read-Back Accuracy¹ 1 Year (over USB or front panel with respect to actual output (@ 25 °C ±5 °C), (% of Output + Offset)

Voltage: 0.05% + 5 mV
Current: 0.15% + 5 mA

Ripple and Noise (with outputs ungrounded, or either output terminal grounded, 20 Hz to 20 MHz)

Voltage: < 0.35 mVrms
< 2 mV p-p
Current: < 2 mArms
Common Mode Current: < 1.5 μArms

Load Regulation ±(% of Output + Offset) Change in output voltage or current for any load change within ratings.

Voltage: < 0.01% + 2 mV
Current: < 0.01% + 250 μA

Line Regulation ±(% of Output + Offset) Change in output voltage or current for any load change within ratings.

Voltage: 0.01% + 2 mV
Current: 0.01% + 250 μA

Programming Resolution

Voltage: 1 mV
Current: 0.21 mA

Read-Back Resolution

Voltage: 1 mV
Current: 0.1 mA

Meter Resolution

Voltage: 1 mV
Current: 0.1 mA

Transient Response Time

Less than 30 usec for output recover to within 15 mV following a change in output current from full load to half load or vice versa.

Command Processing Time via GPIB

Read-Back Commands: Maximum time to read-back output by MEASure? < 20 ms commands

Output Programming Range (maximum programmable values)

Voltage: 0 to 37.8 V
Current: 0 to 7.35 A

Temperature Coefficient ±(% of Output + Offset)

Maximum change in output / read-back per °C after a 30-minute warm-up.

Voltage: 0.01 % + 3 mV
Current: 0.02 % + 3 mA

Stability (% of Output + Offset)

Maximum change in output / read-back per °C after a 30-minute warm-up.

Voltage: 0.02 % + 1 mV
Current: 0.1 % + 1 mA

Voltage Programming Speed

Maximum time required for output voltage to settle within 1 % of its total excursion (for resistive load). Excludes command processing time.

Full Load Up (0V ~ 36V): < 40 ms

Full Load Down (36V ~ 0V): < 40 ms

No Load Up (0V ~ 36V): < 20 ms

No Load Down (36V ~ 0V): < 400 ms

General Specifications²

Item	Limitation & Description
Power Supply :	100V ~ 120V (115V Range) 220V ~ 240V (230V Range)
Power Line (Hz) :	47Hz ~ 63Hz
Interfaces :	Optional USB / USB&GPIB
Power Consumption :	400VA Maximum
Size & Weight for Rack (WxHxD) :	214.6 x 88.6 x 280 mm, < 2500 g (5.5 Lbs)

1. The accuracy specifications are gained under 1-hour warm-up condition and the calibration at 25 °C.
2. For more information, please check the user's manual.



P9611A Specifications

Output Ratings (@ 0 °C ~ 40 °C)

Voltage: 0 to 60 V
Current: 0 to 6 A

Programming Accuracy¹ 1 Year (@ 25 °C ±5 °C), (% of Output + Offset)

Voltage: 0.05% + 10 mV
Current: 0.2% + 10 mA

Read-Back Accuracy¹ 1 Year (over USB or front panel with respect to actual output (@ 25 °C ±5 °C), (% of Output + Offset)

Voltage: 0.05% + 5 mV
Current: 0.15% + 5 mA

Ripple and Noise (with outputs ungrounded, or either output terminal grounded, 20 Hz to 20 MHz)

Voltage: < 0.5 mVrms
< 3 mV p-p
Current: < 2 mArms
Common Mode Current: < 1.5 μArms

Load Regulation ±(% of Output + Offset)

Change in output voltage or current for any load change within ratings.

Voltage: < 0.01% + 2 mV
Current: < 0.01% + 250 μA

Line Regulation ±(% of Output + Offset)

Change in output voltage or current for any load change within ratings.

Voltage: 0.01% + 2 mV
Current: 0.01% + 250 μA

Programming Resolution

Voltage: 1 mV
Current: 1 mA

Read-Back Resolution

Voltage: 1 mV
Current: 0.21 mA

Meter Resolution

Voltage: 10 mV
Current: 1 mA

Transient Response Time

Less than 50 usec for output recover to within 15 mV following a change in output current from full load to half load or vice versa.

Command Processing Time via GPIB

Read-Back Commands: Maximum
time to read-back output by MEASure? < 20 ms
commands

Output Programming Range (maximum programmable values)

Voltage: 0 to 60 V
Current: 0 to 6 A

Temperature Coefficient ±(% of Output + Offset)

Maximum change in output / read-back per °C after a 30-minute warm-up.

Voltage: 0.01 % + 10 mV
Current: 0.02 % + 3 mA

Stability (% of Output + Offset)

Maximum change in output / read-back per °C after a 30-minute warm-up.

Voltage: 0.05 % + 10 mV
Current: 0.15 % + 2 mA

Voltage Programming Speed

Maximum time required for output voltage to settle within 1 % of its total excursion (for resistive load). Excludes command processing time.

Full Load Up (0V ~ 60V): < 100 ms

Full Load Down (60V ~ 0V): < 50 ms

No Load Up (0V ~ 60V): < 35 ms

No Load Down (60V ~ 0V): < 500 ms

General Specifications²

Item	Limitation & Description
Power Supply:	100V ~ 120V (115V Range) 220V ~ 240V (230V Range)
Power Line (Hz):	47Hz ~ 63Hz
Interfaces:	Optional USB / USB&GPIB
Power Consumption:	400VA Maximum
Size & Weight for Rack (WxHxD):	214.6 x 88.6 x 280 mm, < 2500 g (5.5 Lbs)

1. The accuracy specifications are gained under 1-hour warm-up condition and the calibration at 25 °C.
2. For more information, please check the user's manual.

The specifications are subject to change without notice due to design improvements.