

Models 7008, 7034, 7035, 7035R & 7041 Planar Blind-Mate® Connectors, dc to 40.0 GHz



Threadless Connector System / Space Saving / Long Life



Features

- /// **Threadless Connector Mating** - This blind-mate connector series provides threadless connector mating which is useful when mating an array of connectors on one RF module to another array within seconds.
- /// **Space Saving** - These connectors can simplify RF connections in the most inaccessible regions and high package density systems where conventional threaded connector mating is extremely difficult.
- /// **Long Life** - 1,000,000 typical matings. Excellent for ATE applications. Non-piloting spring loaded contact areas provided extremely long life and repeatability.
- /// **Connector Options** - Choose from many standard Connector options such as SMA per MIL-C-39012, 2.92mm (SMK), 2.4mm and SMB.
- /// **Broad Frequency Range** - Aeroflex / Weinschel offers a wide selection of frequency ranges from dc to 40 GHz including most wireless bands.
- /// **Blind-Mate Fixed Attenuator, Termination & dc Block Designs** - Blind-mates can be configured on other coaxial products such as Fixed Attenuators, terminations and even dc blocks.
- /// **Ideal for mass-mount and receiver interface subsystems** where hundreds of high frequency connections need to be made simultaneously.
- /// **New Front & Rear Locking Models** - New designs offer front or rear mounting options.
- /// **Optimized Designs for RF & Wireless Applications**

Description

Planar Blind-mates connectors are typically used as a pair or set which is comprised of two connector subassemblies that have a common mating interface. Generally, a pair contains one floating blind-mate interface with spring loaded inner/outer contacts and the other is a fixed blind-mate interface with fixed inner/outer contacts (Figure 1).

The Planar Blind-mate series provides threadless connector mating which is useful when mating an array of connectors on one RF module to another array within seconds. Each connector pair will tolerate typically 0.02 inches per pair radial and axial offset misalignment and still meet all of its electrical specifications.

Most Aeroflex / Weinschel Planar Blind-mates designs conveniently mount on any panel using a standard panel D-hole or most any standardized hole pattern. Extra heavy construction for long life even with mistreatment makes these blind-mate products suitable for panel use.

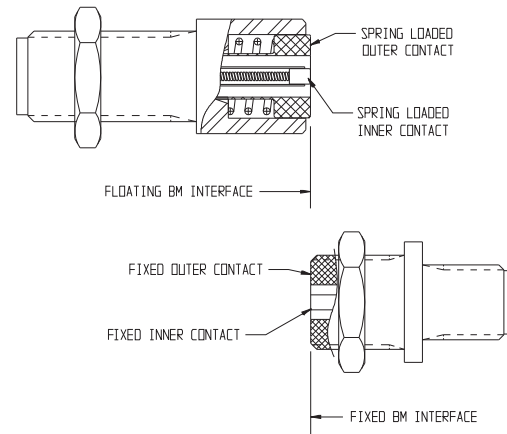



Figure 1. Common Blind-Mate Mating Interface

U.S. Patent Number 6,409,550

EXPRESS Shipment available via 800-542-4457 or www.argosysales.com. Check with distributor for current product stocking quantities.



Blind-Mate Connectors...dc-40.0 GHz

Model Number	Connector Type	Frequency Range (GHz)	SWR (Maximum)	Loss (Maximum dB)	Page No.	
★ 7008	Pressurized SMA Female	dc - 40.0	1.30-1.65*	0.3-1.5*	220	
★ 7034	2.92mm Female, Rear Lock, Floating	dc - 40.0	1.35-1.55*	0.85	221	
★ 7034-1	2.92mm Female, Rear Lock, Fixed	dc - 40.0	1.35-1.55*	0.85		
★ 7035	2.92mm Female, Front Locking Hex Nut, Floating	dc - 40.0	1.35-1.55*	0.85	222	
★ 7035-1	2.92mm Female, Front Locking Hex Nut, Fixed	dc - 40.0	1.35-1.55*	0.85		
7035R	2.92mm Female, Front Locking, Floating, Round Nut	dc - 40.0	1.35-1.55*	0.85		
7035R-1	2.92mm Female, Front Locking, Fixed, Round Nut	dc - 40.0	1.35-1.55*	0.85		
7041	2.92mm Female, Rear Locking, Fixed, Round Nut, Lower Cost	dc - 18.0	1.20-1.40*	0.60	223	

★ EXPRESS Shipment available via www.argosysales.com or 800-542-4457.
 Note: Other models may also be available from Express delivery.

* VARIES WITH FREQUENCY.

Applications

Ideal applications for these high quality/high frequency connectors range from mass-mount and receiver interface subsystems that house hundreds of high frequency connectors to single connector configurations. In either case these connectors allow threadless connector mating which is very useful when mating an array of connectors on one RF module to another array or connector within seconds.

Figure 2 shows a typical application where each connector half contains 7035R series connectors. These connectors contain spring loaded inner/outer contacts which allows for extremely long contact life as well as 0.02 per pair maximum radial and axial offset misalignment while still meeting all the specified electrical specifications.

Aeroflex / Weinschel offers a variety of standard models which are designed to fit or be configured into a wide range of applications:

- /// **Pressurized Designs** - Model 7008 (page 220) is equipped with a flange arrangement designed to withstand 1000 PSI of hydrostatic pressure. This model can be mated with another 7008 or any 7034 or 7035 series Planar Blind-mate. See page 218 for mating applications.
- /// **Rear Locking** - Models 7034 & 7034-1 (page 221) are beneficial in applications where there is easy access to the front of the connector for holding while the cable and connector is added or removed. Rotation is also prevented if the connector front is inserted in a slot which could allow for easier cable and connector assembly installation.
- /// **Front Locking** - Models 7035, 7035-1, 7035R, 7035R-1 (page 222) & 7041 (New..page 223) are beneficial in applications where the cable and connector will be inserted as an assembly into a panel or connector module from the rear.
- /// **Custom Configurations** - Other types of Planar Blind-mate connectors such as SMA, SMB, 3.5mm, flange, microstrip/pc board mount launch, test probes, frequency specific, arrays or interface subsystems can be designed for your particular application. Refer to page 222-224 for other examples.

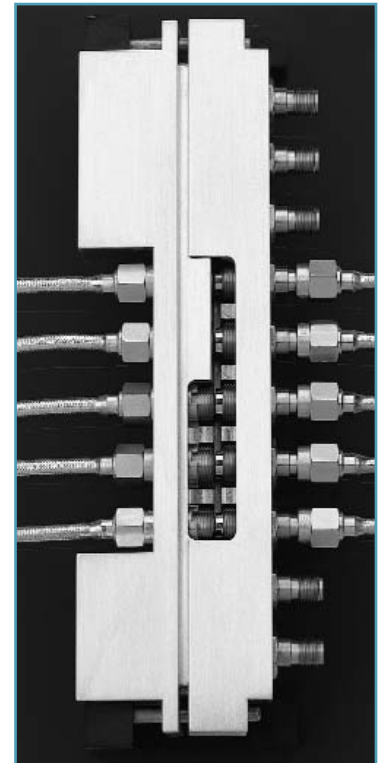
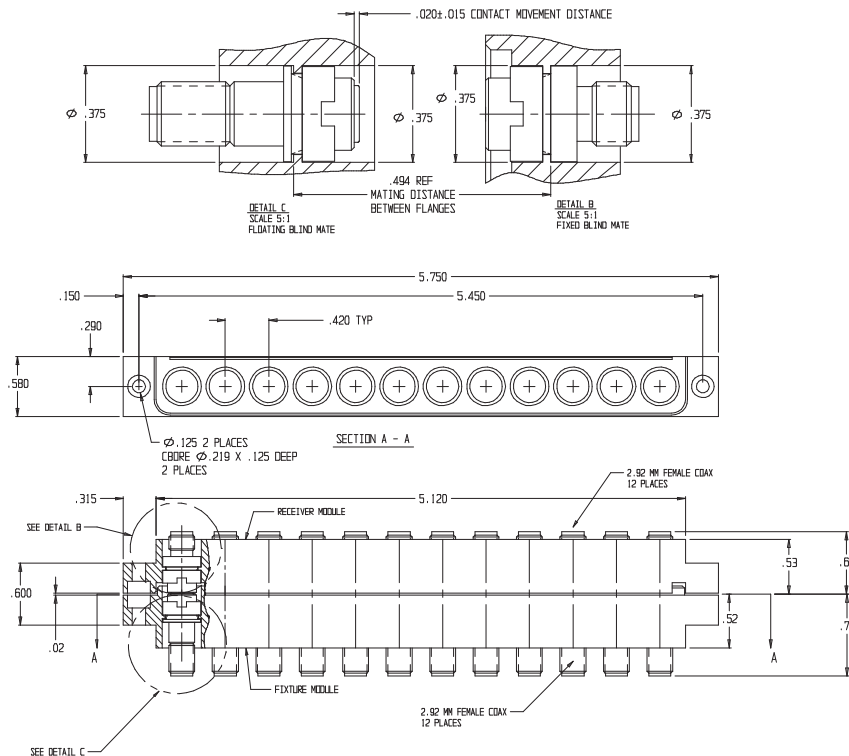

Figure 2. Typical Application

Model 7008
Pressurized Planar Blindmate® Connector

dc to 40.0 GHz

RoHS



Specifications

NOMINAL IMPEDANCE: 50 Ω
FREQUENCY RANGE: dc to 40.0 GHz
POWER RATING: 50 Watts CW, 500 Watts peak

INSERTION LOSS (dB) & SWR*:

Frequency (GHz)	SWR		Loss	
	typical	maximum	typical	maximum
dc - 18	1.20	1.30	0.2	0.3
18 - 26.5	1.30	1.40	0.6	0.8
26.5 - 40	1.45	1.65	1.0	1.5

*Specifications are for mated pair (Mated pair can be any combination of Model 7008 and 7035).

Applications

Model 7034 & 7008:

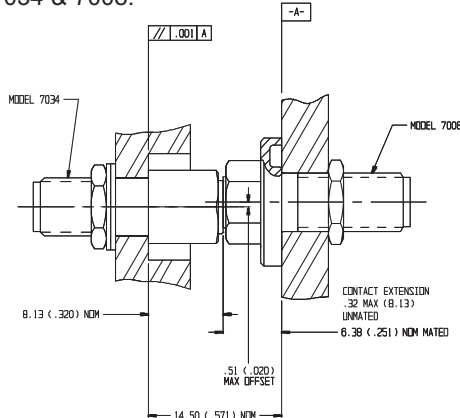

Model 7035 & 7008:

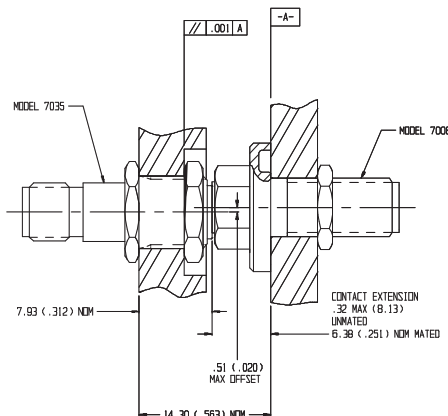

HYDROSTATIC PRESSURE: 1000 PSI
STATIC PRESSURE: 50 PSI
TEMPERATURE RANGE: -50°C to +125°C
CONNECTORS: Stainless Steel SMA connectors per MIL-STD-348 interface dimensions - mate nondestructively with MIL-C-39012 connectors.
WEIGHT: 2 oz (56.7 g) maximum
PHYSICAL DIMENSIONS:

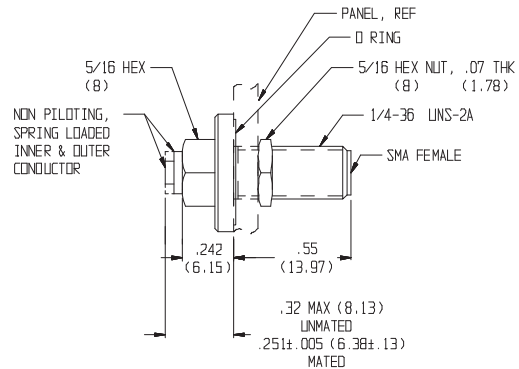

Model 7034-1 & 7008:

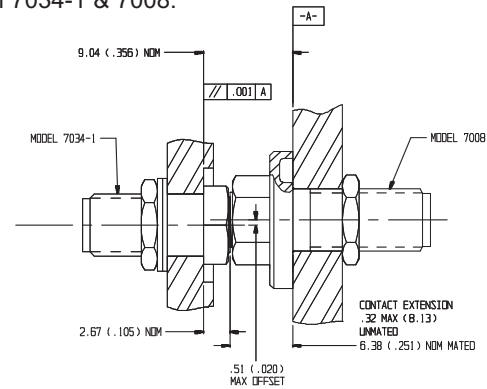

Model 7035-1 & 7008:

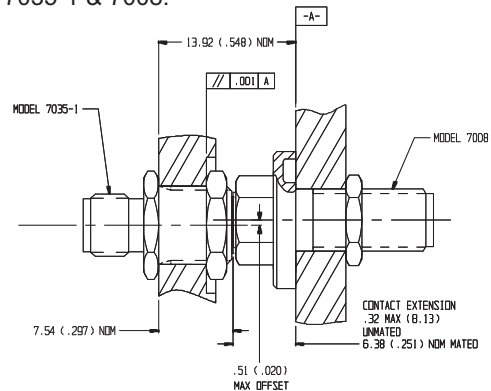

NOTE:

1. All dimensions are given in mm (inches) and are maximum, unless otherwise specified.
2. Unit available with RoHS compliant materials, specify when ordering.

Models 7034 & 7034-1 Rear Locking Planar Blindmate® Connectors

dc to 40.0 GHz

RoHS



INSERTION LOSS (dB) & SWR:

Frequency (GHz)	Loss (maximum)	SWR (maximum)
dc - 18	0.85	1.35
18 - 40	0.85	1.55

Specifications

- NOMINAL IMPEDANCE:** 50 Ω
- FREQUENCY RANGE:** dc to 40.0 GHz
- INSERTION LOSS REPEATABILITY:** ±0.1 dB typical
- MECHANICAL LIFE:** 25,000 matings minimum

RADIAL OFFSET ALLOWED: ±0.02 inches per pair

TEMPERATURE RANGE: -50°C to +100°C

CONNECTORS: Stainless Steel 2.92mm connector with gold plated contacts - mate nondestructively with SMA connectors per MIL-C-39012, 3.5mm, SMK, and other 2.92mm connectors.

WEIGHT: 2 oz, (56.7 g) maximum

PHYSICAL DIMENSIONS:

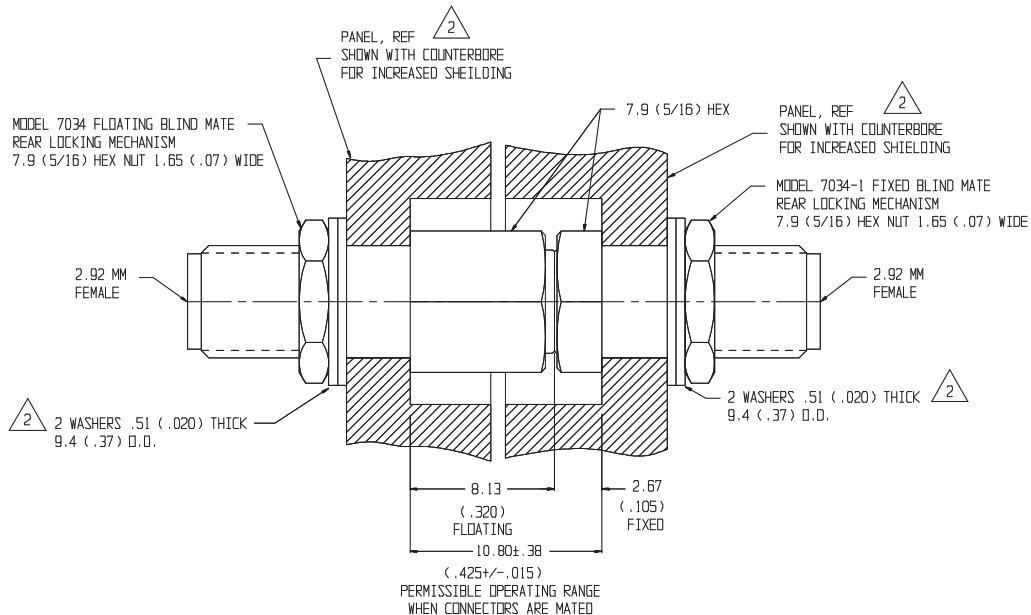

- NOTES:
- All dimensions are given in mm (inches) and are nominal, unless otherwise specified.
 - Maximum panel thickness for Model 7034 is 4.9 (0.195). For panels less than 4.2 (0.165) installation requires appropriate washer.
 - Unit available with RoHS compliant materials, specify when ordering.

Models 7035, 7035-1, 7035R & 7035R-1 dc to 40.0 GHz Front Locking Planar Blindmate® Connectors **☑ RoHS**



INSERTION LOSS (dB) & SWR:

Frequency (GHz)	Loss (maximum)	SWR (maximum)
dc - 18	0.85	1.35
18 - 40	0.85	1.55

Specifications

NOMINAL IMPEDANCE: 50 Ω
FREQUENCY RANGE: dc to 40.0 GHz
INSERTION LOSS REPEATABILITY: ±0.1 dB typical
MECHANICAL LIFE: 25,000 matings minimum

PHYSICAL DIMENSIONS:

Models 7035 & 7035-1:

RADIAL OFFSET ALLOWED: ±0.02 inches per pair
TEMPERATURE RANGE: -50°C to +100°C
CONNECTORS: Stainless Steel 2.92mm connector with gold plated contacts - mate nondestructively with SMA connectors per MIL-C-39012, 3.5mm, SMK, and other 2.92mm connectors.
WEIGHT: 2 oz (56.7 g) maximum

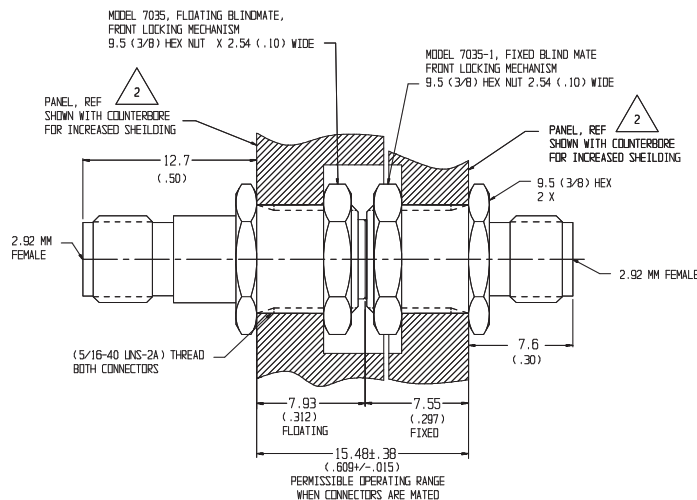

Models 7035R & 7035R-1:

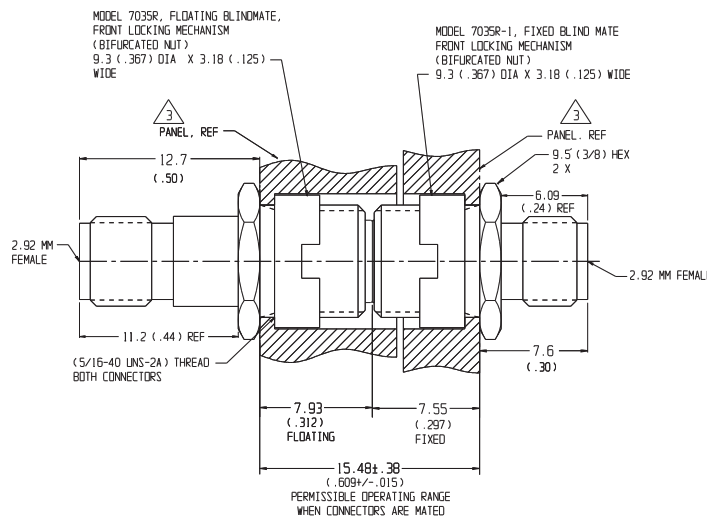

- NOTES:
1. All dimensions are given in mm (inches) and are nominal, unless otherwise specified.
 2. Maximum panel thickness for Model 7035 is 4.9 (0.195).
 3. Panel flange thickness of 1.0 (0.03) shown for 7035R. Connector Mating shown with counterbore for increased shielding effectiveness.
 4. Unit available with RoHS compliant materials, specify when ordering

Models 7041 Rear Locking Planar Blindmate® Connector

dc to 18.0 GHz

Lower Cost Design



Specifications

NOMINAL IMPEDANCE: 50 Ω nominal

FREQUENCY RANGE: dc to 18.0 GHz

INSERTION LOSS (dB) & SWR:

Frequency (GHz)	Loss (maximum)	SWR (maximum)
dc - 6	0.40	1.20
6 - 18	0.60	1.40

INSERTION LOSS

REPEATABILITY: ±0.1 dB typical

MECHANICAL LIFE: 25,000 matings minimum

RADIAL OFFSET ALLOWED: ±0.02 inches per pair

TEMPERATURE RANGE: -50°C to +100°C

CONNECTORS: Stainless Steel 2.92mm connector with gold plated contacts - mate nondestructively with SMA connectors per MIL-C-39012, 3.5mm, SMK, and other 2.92mm connectors.

WEIGHT: 2 oz, (56.7 g) maximum

PHYSICAL DIMENSIONS:

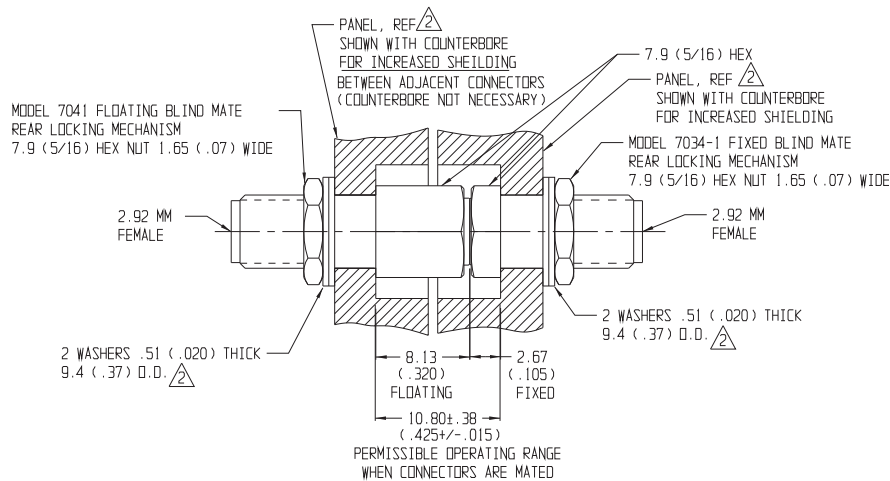
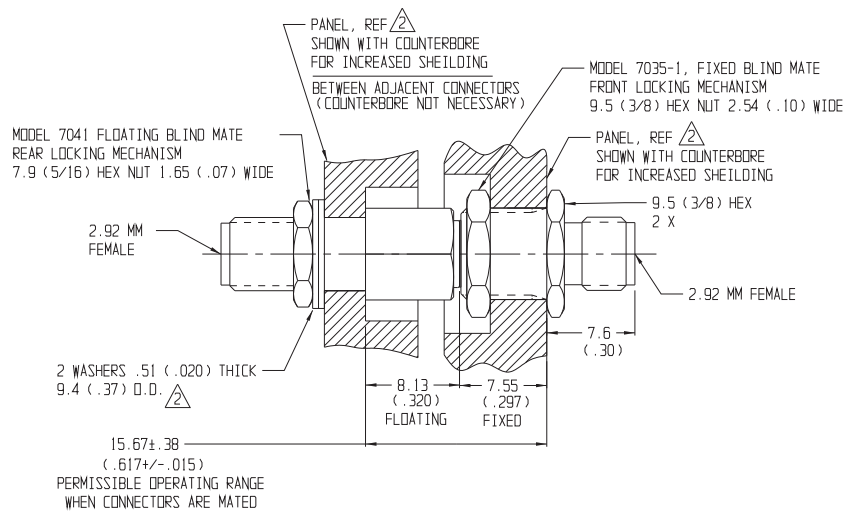

- NOTES: 1. All dimensions are given in mm (inches) and are nominal, unless otherwise specified.
 2. Maximum panel thickness for Model 7041 is 4.9 (0.195). Panel flange thickness less than 4.2 (0.165). Installation requires appropriate washer.
 3. * when mating surface have been maintained and kept clean.

Custom Examples

The following examples illustrate some typical Blind-mate designs that can be either modified or used as a basis for creating a specific blind-mate connector or system for your application:

Example 1:

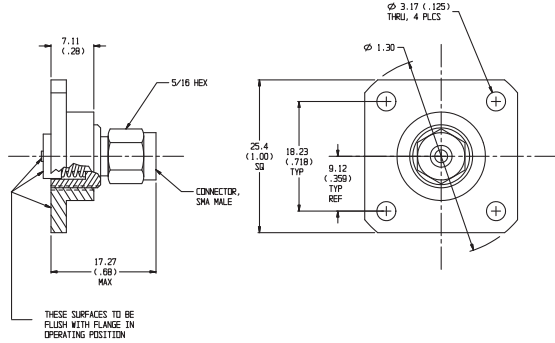

This example shows a blind-mate to SMA flange connector which includes a standard 4 hole mounting pattern and SMA connectors per MIL-C-39012 connectors. These connectors can be optimized to a specific frequency range and/or your defined specifications.

Example 2:

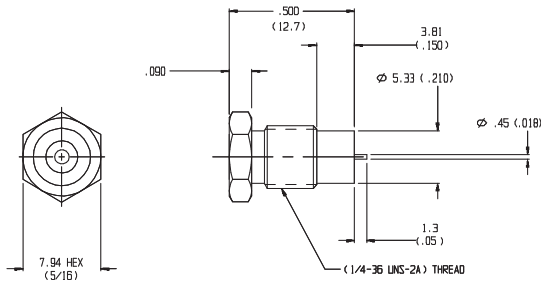

Example 2 illustrates a blind-mate to a microstrip launch design that features a non-piloting (fixed), spring loaded inner connector. Specifications include dc to 4 GHz frequency operation, maximum insertion loss of 0.5 dB and maximum SWR of 1.25.

Example 3:

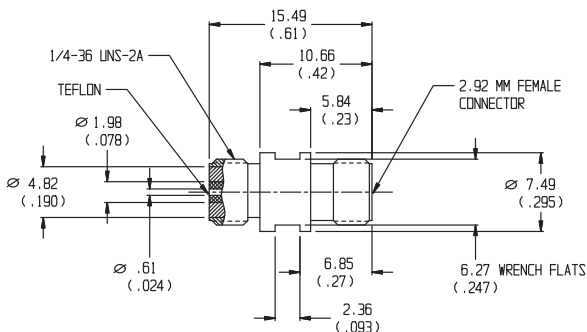

Example 3 illustrates a blind-mate to 2.92mm test probe design that features wrench flats, dc to 18 GHz frequency operation, maximum insertion loss of 6 dB and maximum SWR of 1.25. This was specifically designed to interface with standard SMA, 3.5mm, and 2.92mm Bulkhead connectors.

Example 4:

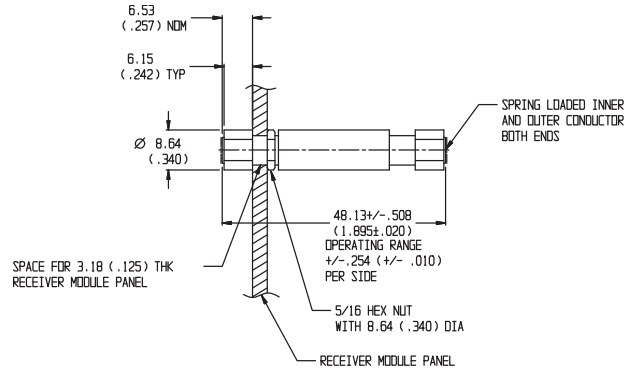

This example illustrates shows a 6 dB blind-mate attenuator design that consists of two floating receivers with a compression spring and spring loaded contacts (inner and outer conductors). Designs can also be supplied with stationary fixed surface connectors. Specifications for this unit include dc-32 GHz operation, 1.35 maximum SWR, and a radial alignment ± 0.02 offset.

Example 5:

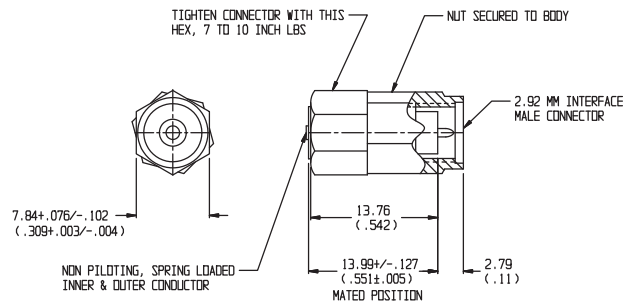

This example illustrates a blind-mate to 2.92mm connector design that features a non-piloting, spring loaded inner and outer connector. Specifications included dc to 40 GHz frequency operation, static pressure of 50 PSI, temperature range of -50°C to +125°C maximum insertion loss of 0.3 to 1.5 and maximum SWR of 1.30-1.70.

Example 6:

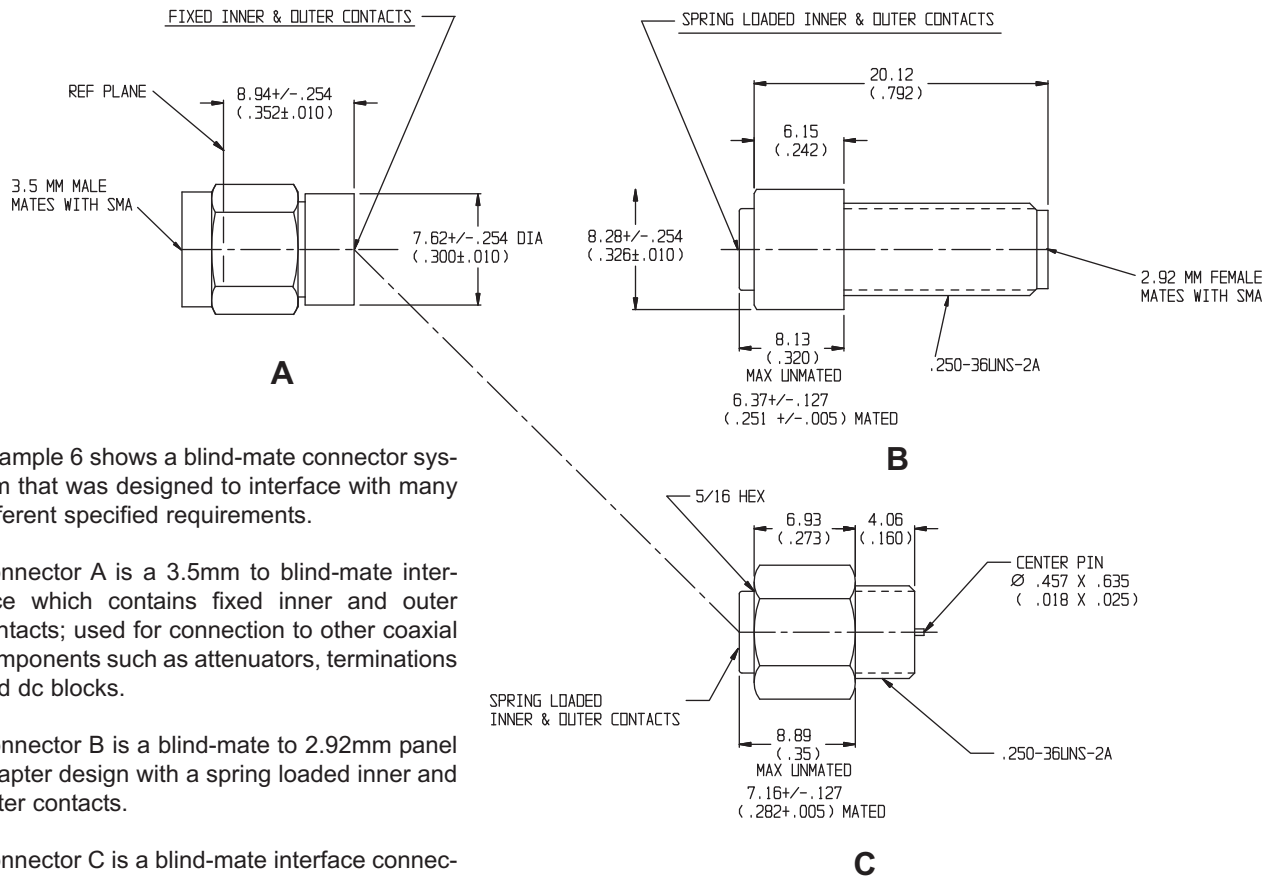

Example 6 shows a blind-mate connector system that was designed to interface with many different specified requirements.

Connector A is a 3.5mm to blind-mate interface which contains fixed inner and outer contacts; used for connection to other coaxial components such as attenuators, terminations and dc blocks.

Connector B is a blind-mate to 2.92mm panel adapter design with a spring loaded inner and outer contacts.

Connector C is a blind-mate interface connector that can be easily installed to coaxial cables or printed circuit board assemblies.

Example 7:

This example illustrates a low cost blind-mate to SMB configuration specifically designed and optimized for RF & wireless applications. These connectors offer not only all the features of the Planar Blind-mate interface but the SMB connector provides an additional quick disconnect for cable assemblies.

Specifications for this connector include dc to 2.0 GHz operation, 50 Ω nominal impedance, insertion loss of 0.35 dB, SWR of 1.15-1.30, radial/axial misalignment of ±0.020" OFFSET (blind-mate side), **operating temperature of +10°C to +40°C**, dielectric withstanding voltage of 1000 Vac and a insulation resistance of **1000 MΩ nominal**.

These stainless steel connectors contain non-piloting contacts that provides long life (1,000,000 matings) and offers a repeatability of ±0.05 dB typical.

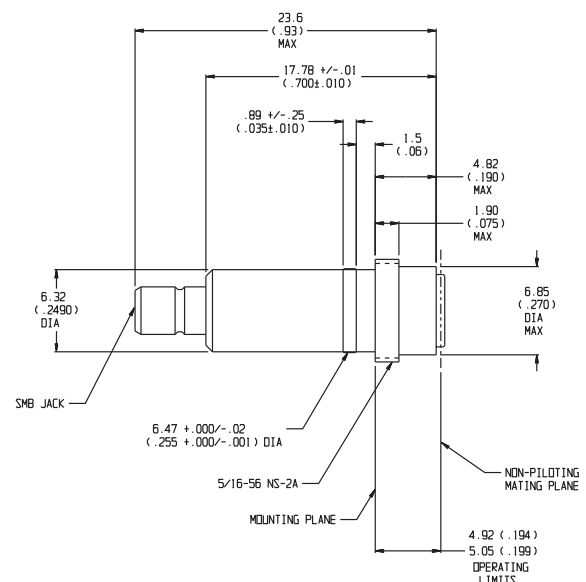

NOTE: All dimensions are given in mm (inches) and are maximum, unless otherwise specified.

Example 8: 16 Way Power Divider - High Density Packaging Environment

This example shows how a series of blind-mate connectors are used in a 16 Way Power Divider module that is used in a high density packaging environment.

Specifications

Frequency Range:	30 MHz - 3 GHz
Impedance:	50 ohms nominal
Isolation:	23.5 minimum
RF Input Power:	1 Watt maximum (any port)
Operating Temperature Range:	0 to 60 °C

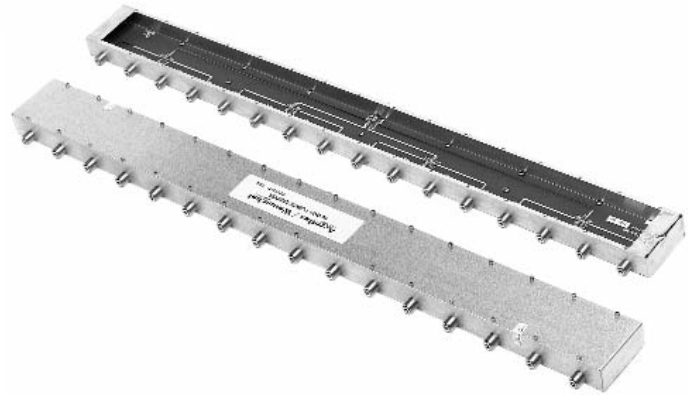

PHYSICAL DIMENSIONS:

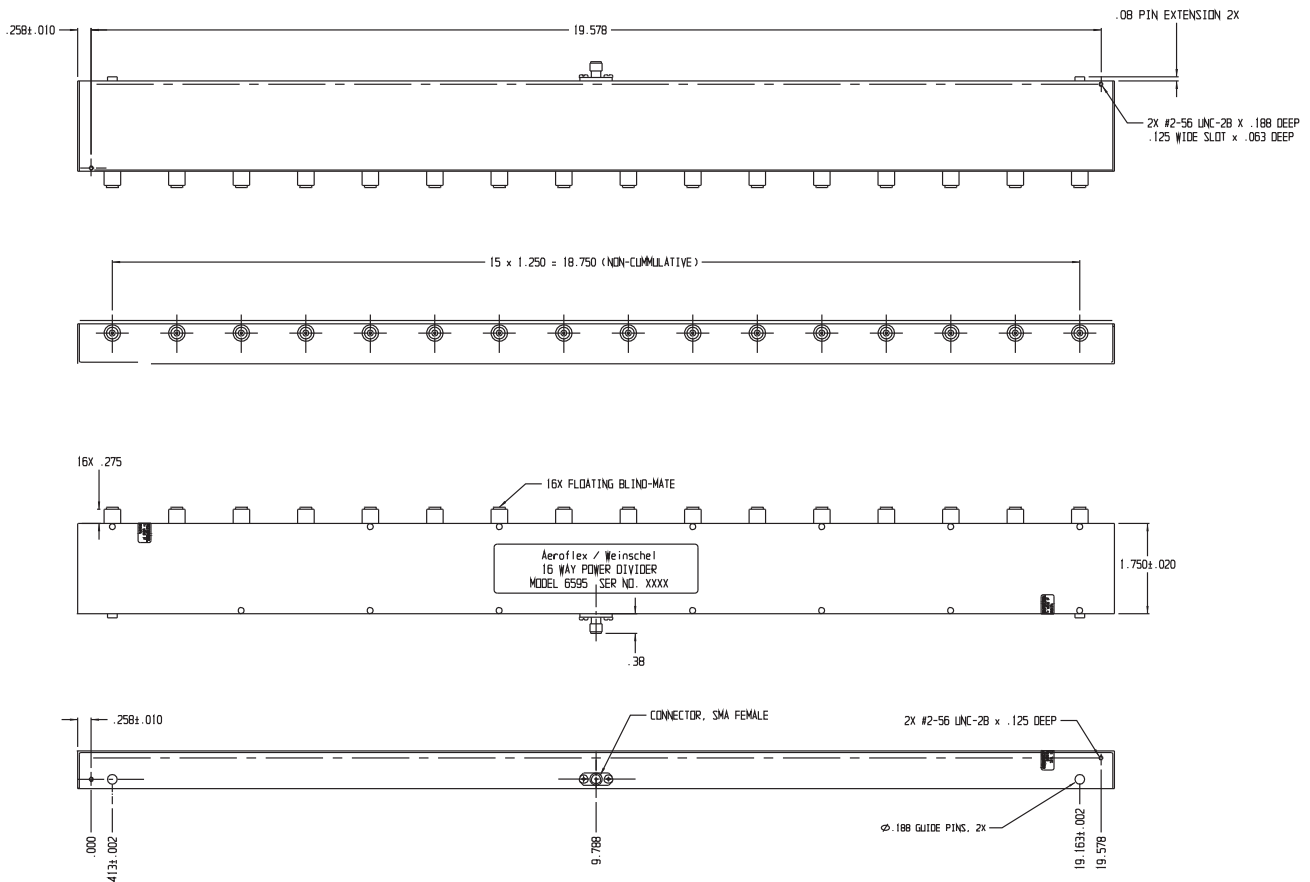

NOTES: All dimensions are given in inches and are nominal, unless otherwise specified.